



parpas

DIAMOND linear



philosophy and design technology

Maschinen-Philosophie und Kinematik

In designing the DIAMOND machine the choice has fallen on the gantry structure concept design due to the main importance of

WORKPIECE HELD IN A STEADY POSITION

This allows maximum speed and accuracy as moving masses are always constant and known

WORKPIECE WEIGHT = VARIABLE MASS
MOVING AXES = CONSTANT MASS

Die DIAMOND wurde als obenliegendes Gantry konzipiert, um folgenden Effekt zu erreichen

DAS WERKSTÜCK BEWEGT SICH NICHT

Hierdurch können eine sehr hohe Dynamik, sowie exzellente Genauigkeit erreicht werden, da konstante und bekannte Massen bewegt werden

WERKSTÜCK = VARIABLE MASSE
BEWEGTE AXSEN = KONSTANTE MASSEN

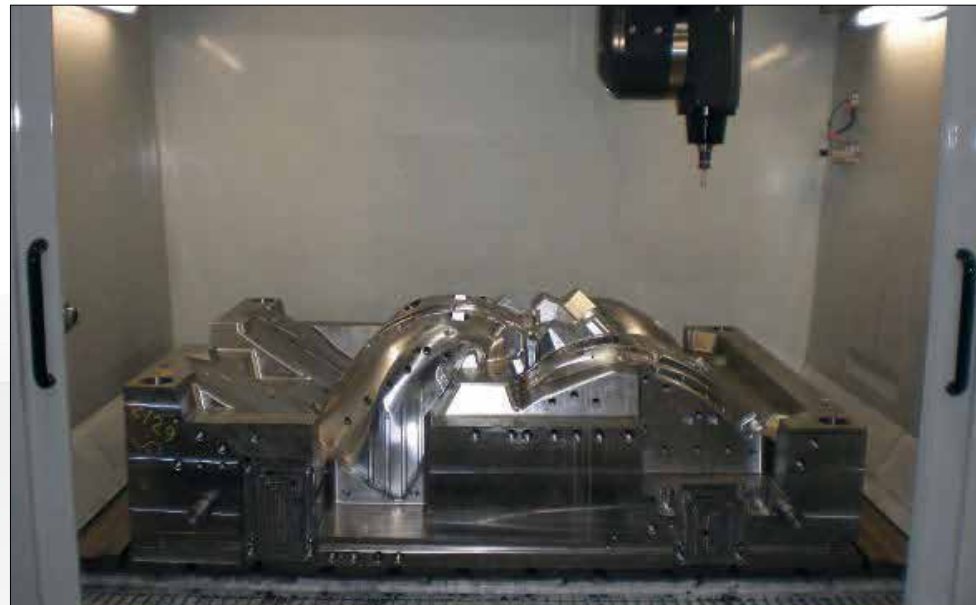



technology / Technology

1. AXES X Y Z with linear motors
2. Axes A C with torque motors (direct drive)
3. Structure of the machine fully isolated and thermo stabilized **PATENTED**
4. Bed, table, columns **MONOLITIC**

1. ACHSEN X, Y, Z Angetrieben durch Linearmotoren
2. Achsen A und C direkt angetrieben durch Torque-Motoren
3. Maschinenstruktur komplett isoliert und thermisch stabilisiert (**Patent**)
4. **Monoblock-Aufbau** bestehend aus Bett, Tisch und Seitenwänden

targets / Ziele



Design an HIGH DYNAMIC MILLING MACHINE capable of:

1. Best dynamic in terms of acceleration and speed
2. Best structural rigidity
3. Best cutting performance
4. Best volumetric accuracy
5. Best safety
6. Best environment respect
7. Best operative ergonomic
8. Less possible overall dimension

Entwerfen einer HOHEN DYNAMISCHEN FRÄSMASCHINE mit:

1. Maximale Dynamik in Beschleunigung und Vorschub
2. Maximale Steifigkeit der Struktur
3. Maximale Zerspanungs-Performance
4. Maximale volumetrische und Prozess-sichere Genauigkeit
5. Maximale Sicherheit
6. Maximale Ergonomie
7. Minimale Umweltbelastung
8. Minimaler Platzbedarf

accuracy thermostatic system

Thermo-stabilisierte Genauigkeit

Over ten years experience in thermal stabilization of the machine structures, see XS, FORMULA, INVAR etc., in ensuring the consistency of the machine accuracy in presence of ambient temperature changes, the gantry of the DIAMOND is completely insulated and thermo stabilized thanks to a patented thermal conditioning system, avoiding structural distortions caused by variations in the ambient temperature.

Über 10 Jahre Entwicklung und Erfahrung in der thermischen Stabilisierung von Fräsmaschinen (XS, FORMULA, INVAR etc.) sind in die DIAMOND eingeflossen. Als Ergebnis ist die DIAMOND komplett thermisch isoliert und stabilisiert und somit zuverlässig genau, auch in einem thermisch veränderlichen Umfeld.

6

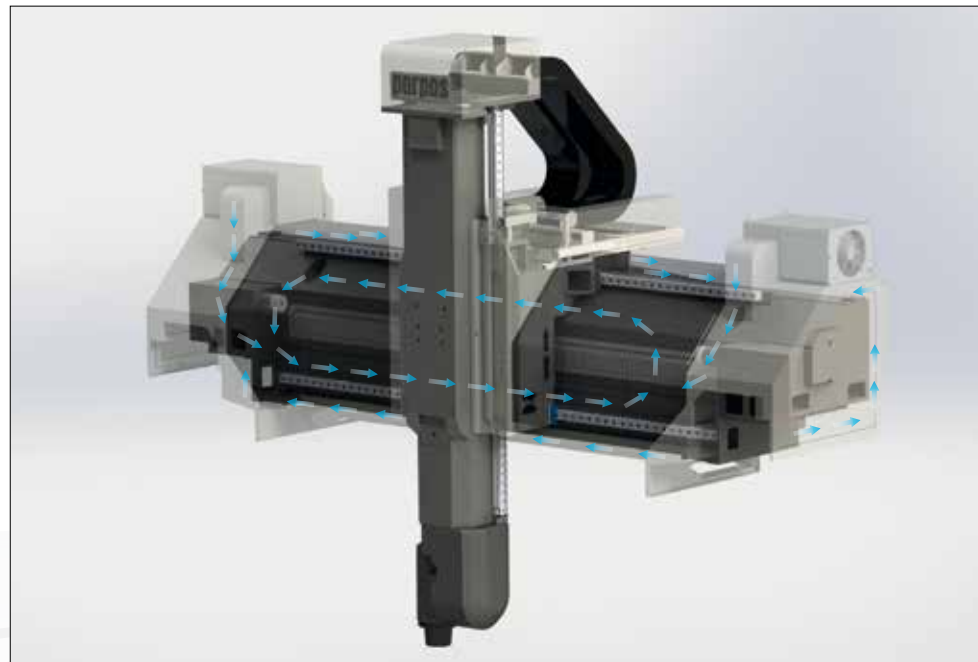

integral BOX structure

Geschlossener Aufbau

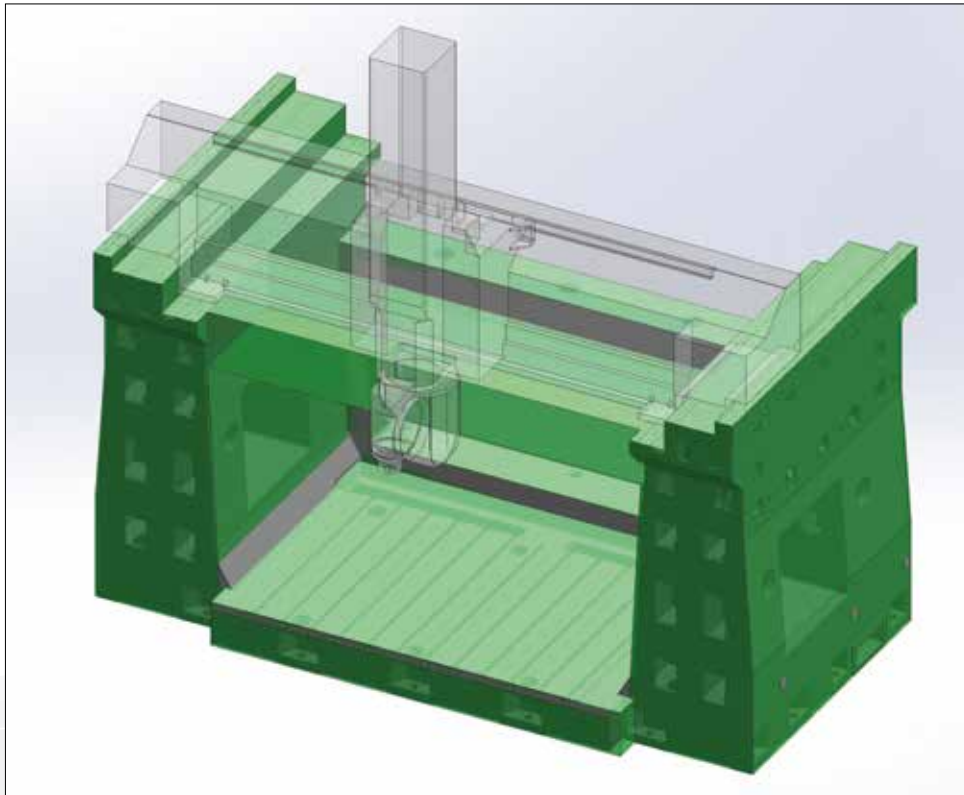

designing / Konstruktion

The designing process of all structural components for the machine has been accomplished by the most advanced and powerful software for the structural analysis (FEM), static analysis and dynamic analysis to achieve better speed performances and best accuracies (to reduce the machining times).

Specific efforts have been made in the research phase, by our technological departments, on the basic materials and on the components (mechanical, electronic and software) using the most advanced technologies developed in the aerospace industry and racing car industry.

The technological parameters are dictating that to obtain higher speeds and higher dynamic accuracy it is necessary to design and develop structures **with less weight and more rigidity (steel instead of cast iron)**

Die Aufgabe der Entwicklung war es, höchste Dynamik und Genauigkeit in der Maschine zu erreichen. Hierzu mussten dynamische Bauteile entwickelt werden, welche bei möglichst geringem Gewicht eine sehr hohe Steifigkeit bieten. Aus diesem Grund wurde Stahl für die bewegten Teile gewählt. Außerdem wurden spezielle Werkstoffe verwendet, welche ursprünglich für den Motorsport und den Flugzeugbau entwickelt wurden.

Die Konstruktion der DIAMOND erfolgte unter Zuhilfenahme der modernsten Software zur FEM-Analyse. Hierdurch war es möglich bereits während des Konstruktionsvorgangs eine tiefgehende statische und dynamische Analyse der verschiedenen Bauteile durchzuführen. **Diese Reihenfolge scheint mir logischer – erst die Aufgabe, dann die Umsetzung.**

some static and dynamic analysis

Einige statische und dynamische Analysen

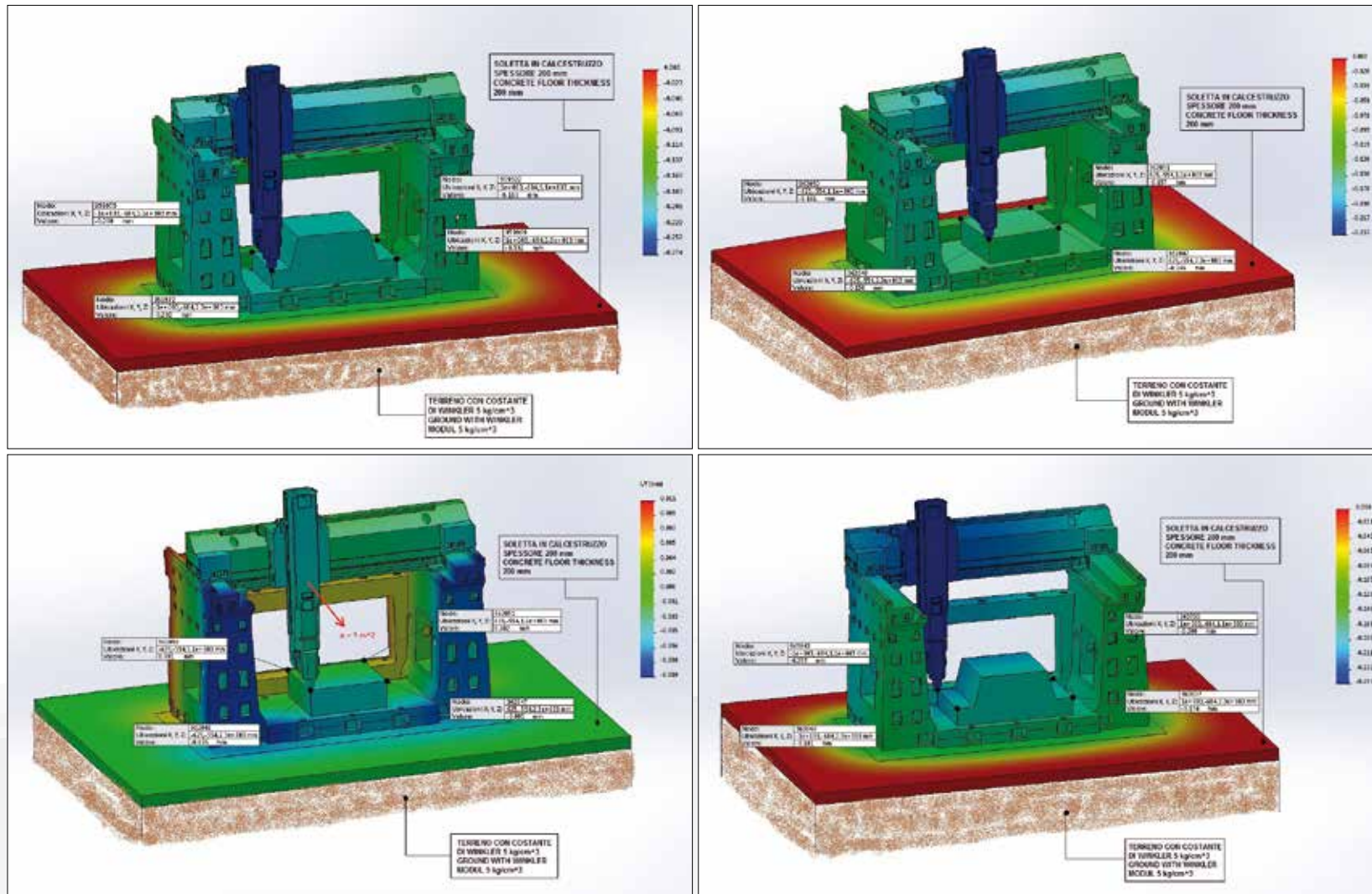

TABLE It is an integral part of the bed structure and on the surface there are the T slots used to clamp the various parts to be machined. N°2 T slot in H7 grade allow precise clampings
Thanks to the stiffness and higher thickness of the basements, the load capacity is 22500 kg

OVERHEAD CROSS RAIL It is built in welded steel duly ribbed and duly stabilized, with **accurate magneto-static check of the weldings (MAGNAFLUX)**. At the two ends of the slide there are the carriages for its movement along the main structure as previously described.
On the front of the cross slide there are the guideways for the cross movement of the saddle and of the ram supporting the milling head.

RAM CARRIAGE SADDLE Duly dimensioned to support the dynamics of the ram on its movement, it is built in ribbed double wall U shaped steel. In the back there are 4 preloaded rollers for the movement along the cross rail.

RAM The ram supporting the milling head is performing the vertical movement with linear motors. It is made in duly stabilized welded steel with **accurate magnetostatic control of the weldings (MAGNAFLUX)**. It has double wall structure to ensure the maximum rigidity. The ram is guided and slides on 2 linear ways with pre-loaded rollers and linear motor.

TISCH Der Tisch ist ein integraler Bestandteil der Maschinenstruktur. In die Oberfläche sind T-Nuten zum Spannen der Werkstücke eingearbeitet. 2 H7-Richtnuten dienen der Ausrichtung.
Dank des überaus steifen Aufbaus können Werkstücke bis 22500 kg aufgenommen werden.

TRAVERSE Die Traverse ist aus Stahl geschweißt, kräftig verrippt und Stabilisiert. **Die Schweißnähte wurden im MAGNAFLUX-Verfahren magneto-statisch überprüft.** Seitlich wird die Traverse auf den Seitenwangen der monolithischen Grundstruktur geführt. Vorn an der Traverse befinden sich die Führungen des Kreuzschlittens, welcher den Frässlitten und den Fräskopf trägt.

KREUZSCHLITTEN Der Kreuzschlitten ist U-förmig, doppelwandig und aus verripptem Stahl gefertigt. Auf seiner Rückseite befinden sich 4 Führungsschuhe für die Bewegung entlang der Traverse.

FRÄSSCHLITTEN Der Frässlitten trägt den Fräskopf und verfährt linear angetrieben vertikal auf dem Kreuzschlitten. **Er ist aus Stahl gefertigt, doppelwandig und großzügig dimensioniert.** Er verfährt auf 2 vorgespannten Linearführungen auf dem Kreuzschlitten.



plastic mould / Spritzgieß-Formen



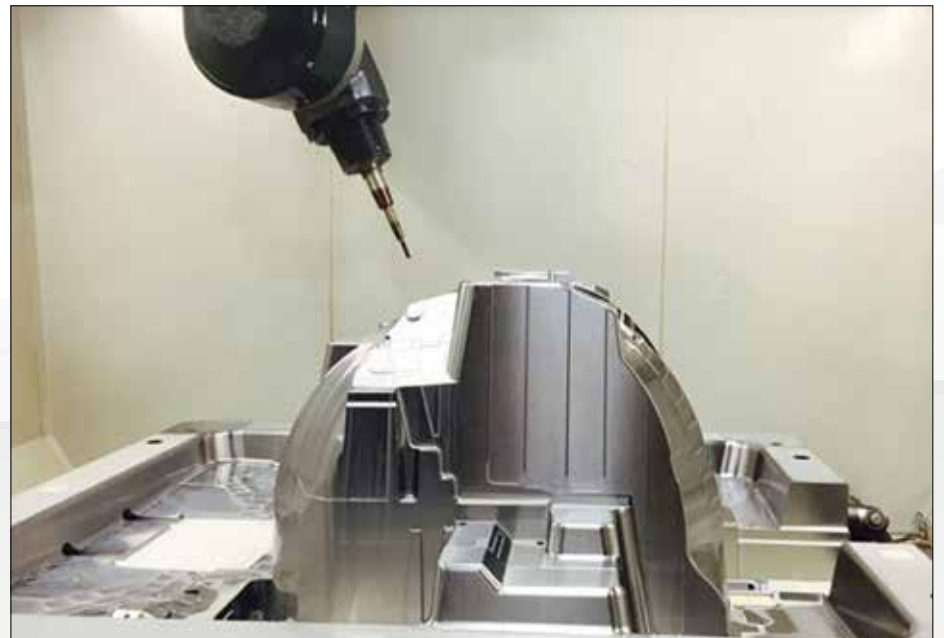
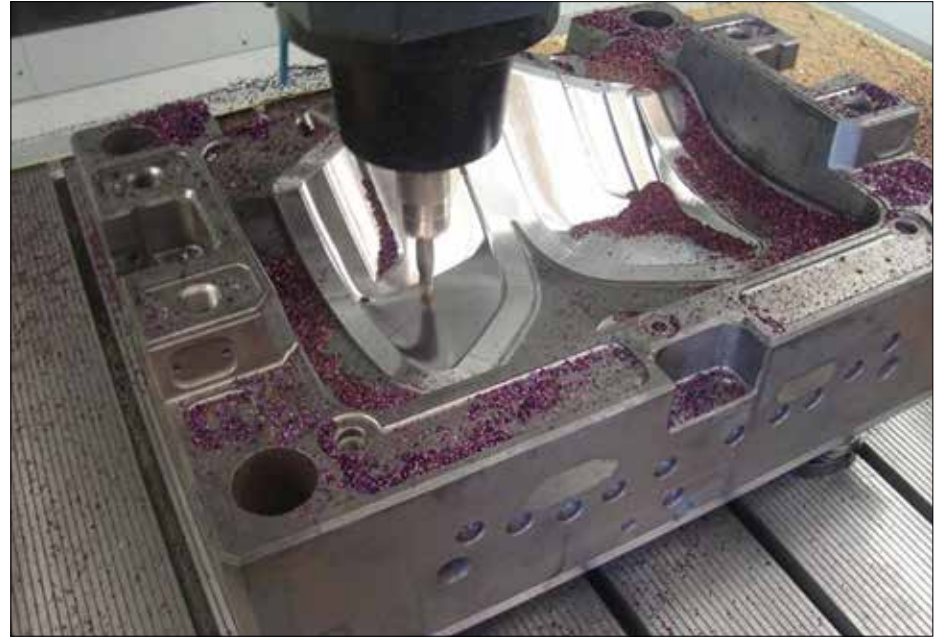

stamping dies

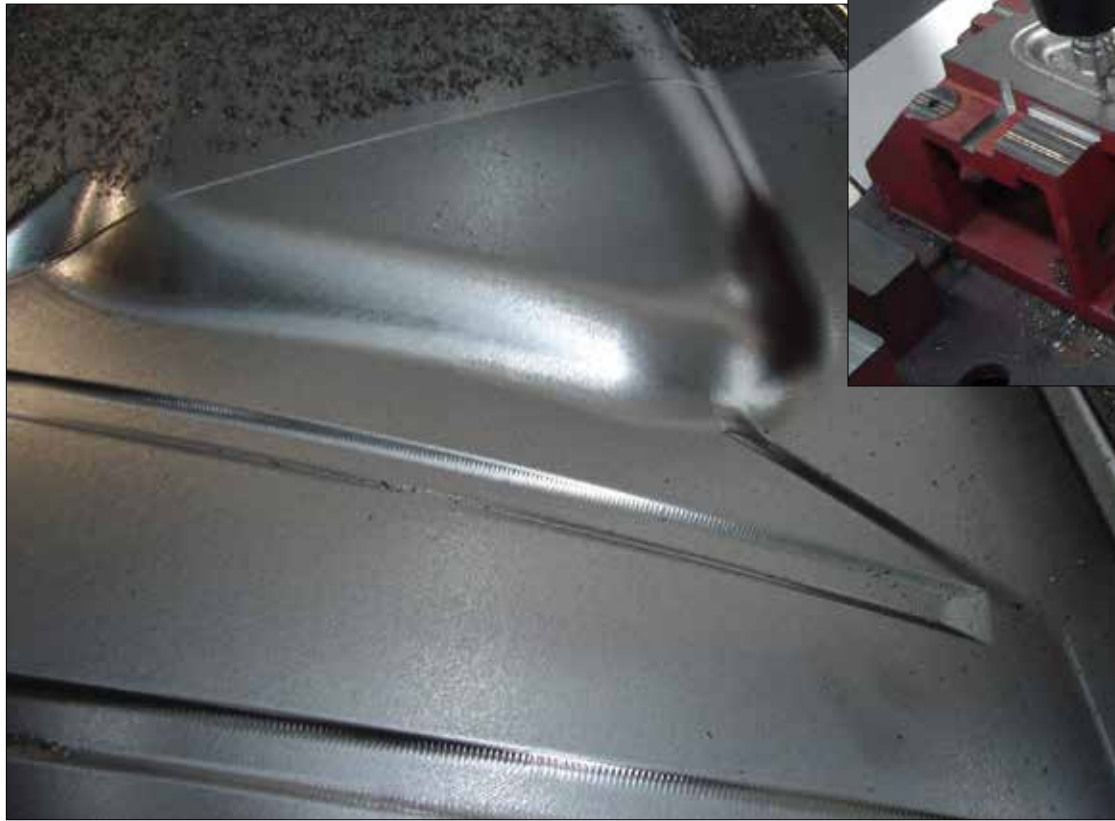

Blech-Werkzeuge

milling - turning / Fräsen - Drehen

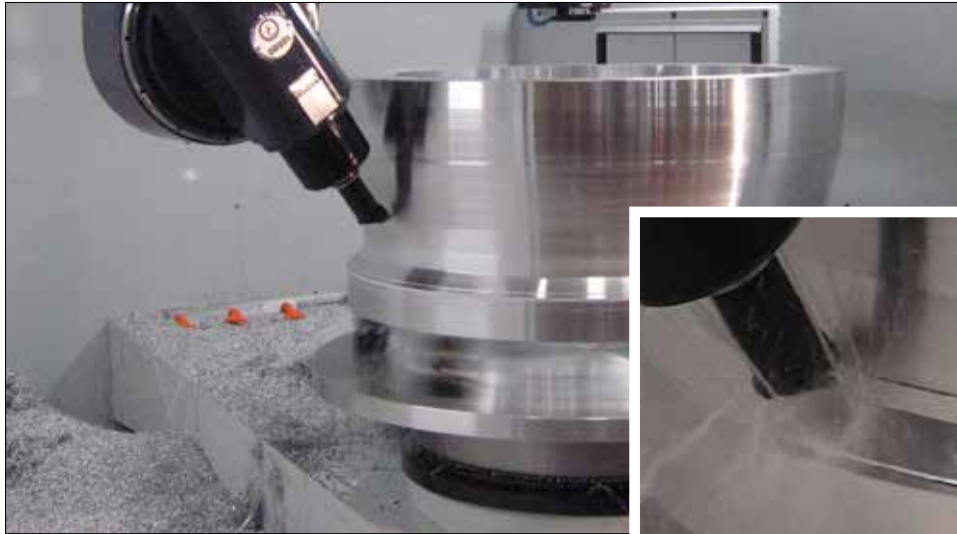

TOE head - why orthogonal axes

TOE-Kopf - Warum orthogonal?

The shape of the TOE head has been designed to reduce drastically the length of the tools when machining in deep cavities. For the same reason, the electrospindle has a longer snout compared to the standard spindles.

Quite evident are the advantages to work with shorter tools

- 1. Less vibrations**
- 2. Better machined surface quality**
- 3. Higher machining feed rates**
- 4. Longer tool life**
- 5. Easier programming and easier anti-collision check**

Die Form des TOE wurde gewählt um die Länge der Werkzeuge in tiefen Kavitäten drastisch zu reduzieren. Aus demselben Grund ist die Spindel Nase länger, als bei Standard-Spindeln.

Die offensichtlichen Vorteile kurzer Werkzeuge:

- 1. Weniger Vibrationen**
- 2. Höhere Oberflächengüte**
- 3. Höhere Bearbeitungs-Vorschübe**
- 4. Höhere Werkzeug-Standzeiten**
- 5. Leichtere Programmierung und Kollisions-Vermeidung**

Orthogonal head TOE 29T

Orthogonal-Fräskopf TOE 29T

TECHNICAL DATA

C-axis rotation (indexing)	deg.	± 370
Clamping torque C-axis	Nm	5000
A-axis rotation (indexing)	deg.	± 105
Clamping torque A-axis	Nm	4000
A-axis pivot length	mm.	340
Spindle taper	HSK	63 A
Spindle speed max	rpm	20000
Spindle power max	kW	37
Spindle torque max	Nm	115
Speed range in constant power	rpm	3000 ÷ 20000
Speed range in constant torque	rpm	0 ÷ 3000

Milling and turning option

TECHNISCHE DATEN

C-Achsen-Rotation	Grad	+/-370
Klemm-Moment A-Achse	Nm	5000
A-Achsen-Rotation	Grad	+/-105
Klemm-Moment C-Achse	Nm	4000
A-Achsen Pivot-Länge	mm	340
Werkzeugaufnahme	HSK	63A
Drehzahl max.	min-1	20 000
Leistung max.	kW	37
Drehmoment	Nm	115
Drehzahl mit konstanter Leistung	min-1	3 000 - 20 000
Drehzahl mit konstantem Drehmoment	min-1	0 - 3 000

Fräsen-Drehen Option



machine data / Technische Daten Maschine

Travels: Longitudinal (X axis)	mm 1500 (+ 330)	Verfahrwege: (X-Achse)	mm 1500 (+ 330)
Cross (Y axis)	mm 2200 (+ 330)	(Y-Achse)	mm 2200 (+ 330)
Vertical (Z axis)	mm 1000	(Z-Achse)	mm 1000
Table surface	mm 1600 x 2350	Tischgröße	mm 1600 x 2350
T slots	mm 22	T-Nuten	mm 22
Distance between T slots	mm 200	Abstand	mm 200
Load capacity	kg 22500	Tischbelastung	kg 22500
Distance between columns	mm 2905	Lichte Weite zwischen Seitenwangen	mm 2905
Clearance below the spindle	mm 1250 (TOE 29T)	Abstand Spindel-nase-Tisch	mm 1250 (TOE 29T)
Feed rate	axes X - Y m/1' 0 ÷ 60 axis Z m/1' 0 ÷ 40	Vorschub	Z-Achse X - Y m/1' 0 ÷ 60 X- und Y-Achse Z m/1' 0 ÷ 40

18

options / Optionen

FULL 5 AXIS TOE HEAD
 HEAD TOE 41T 15000 rpm HSK100A / 16000 rpm HSK 63A
 MILLING AND TURNING SPINDLE
 ATC 24 - 120
 ROOF
 FUMES ASPIRATION SYSTEM
 THROUGH SPINDLE COOLANT 30 - 50 bar
 LASER TOOL PRESETTING
 TOUCH PROBE
 REMOTE HANDWHEEL
 WIRELESS REMOTE HANDWHEEL
 PALLET AUTOMATION SYSTEMS

5-Achsen interpolierend
 Fräskopf TOE 41T mit
 15000 min-1 (HSK 100) 16000min-1 (HSK 63A)
 Dreh- Frässpindel und Drehtisch
 Werkzeugwechsler 24-120 Plätze
 Dach
 Nebel-/Staubabsaugung
 IKZ 30-50 bar
 Laser-Werkzeugvermessung
 Messtaster
 Elektronisches Handrad (Kabel oder Funk)
 Automatischer Palettenwechsler

large working range with small foot print
Großer Arbeitsraum bei geringem Platzbedarf

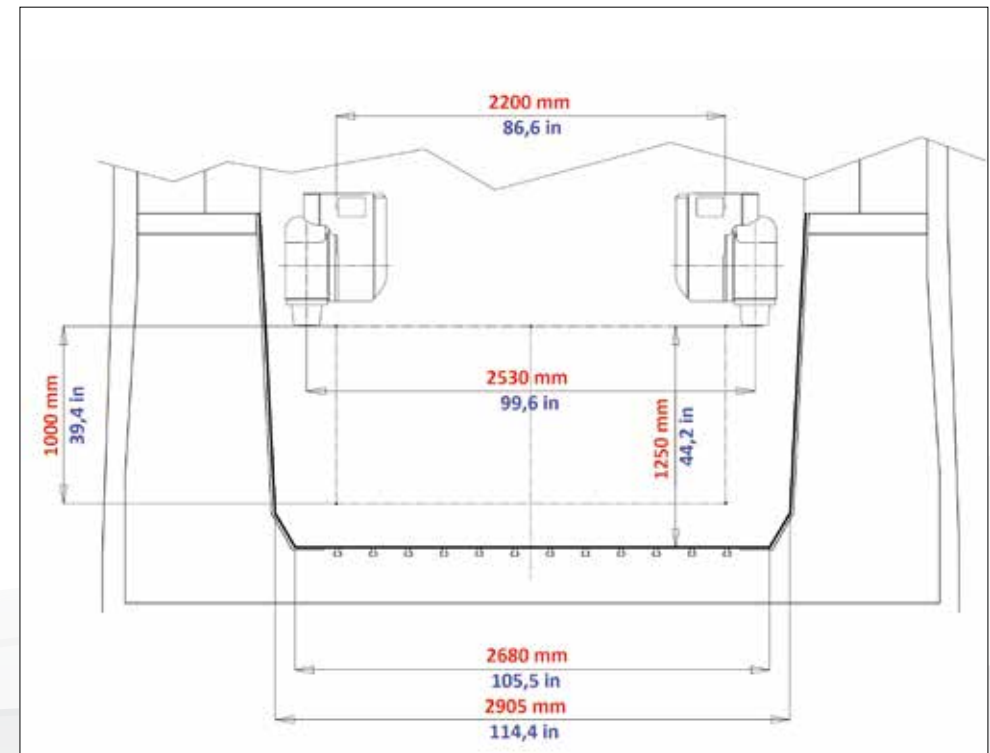
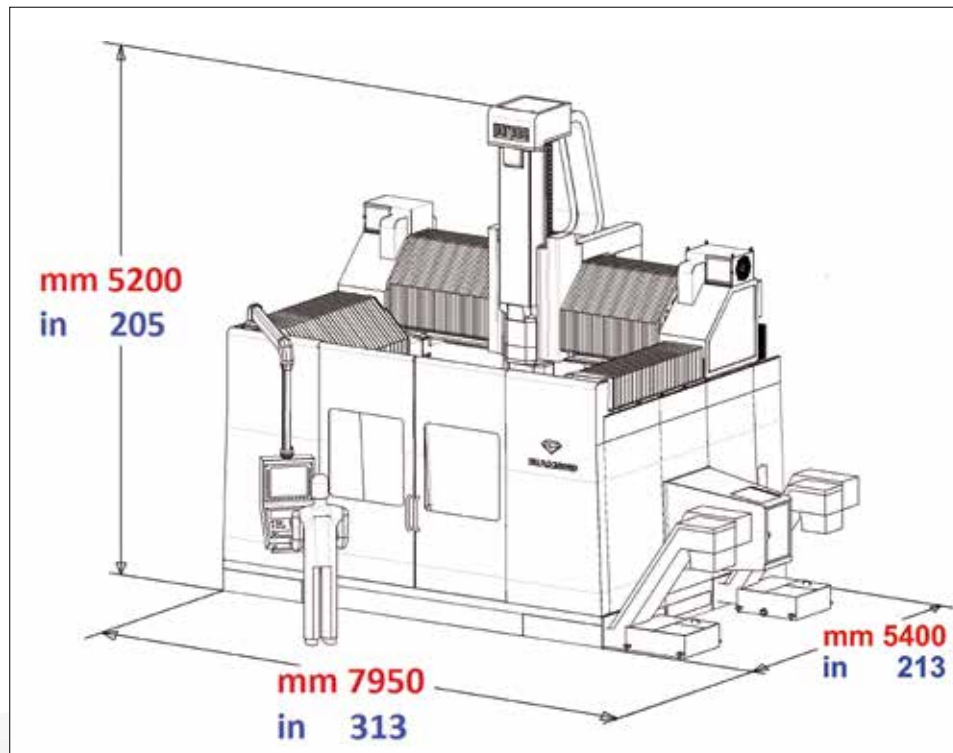

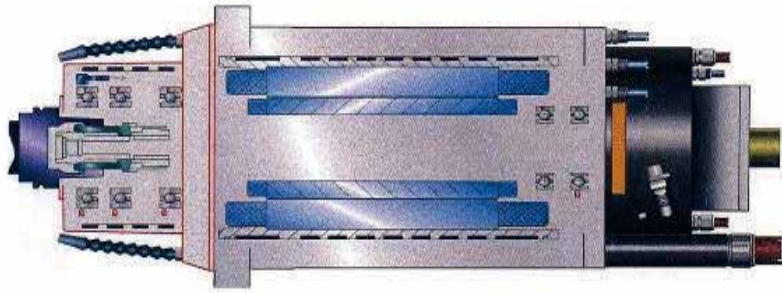

motor spindle
Motorspindel



automation / Automation

HEIDENHAIN TNC 640

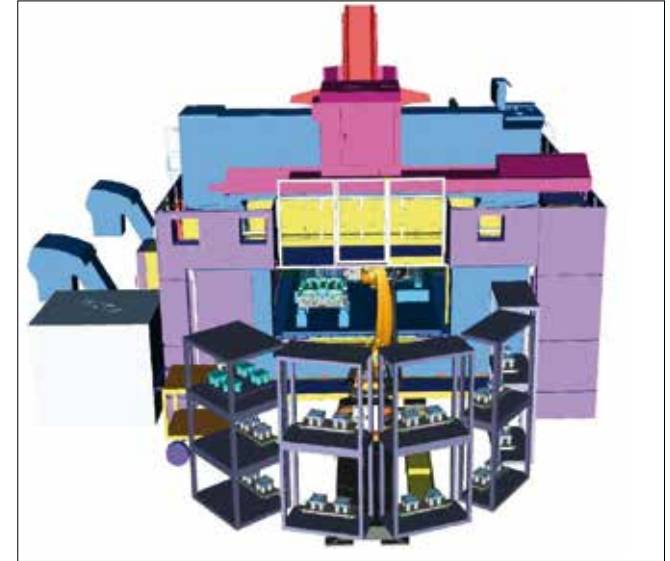

SINUMERIK 840D SL

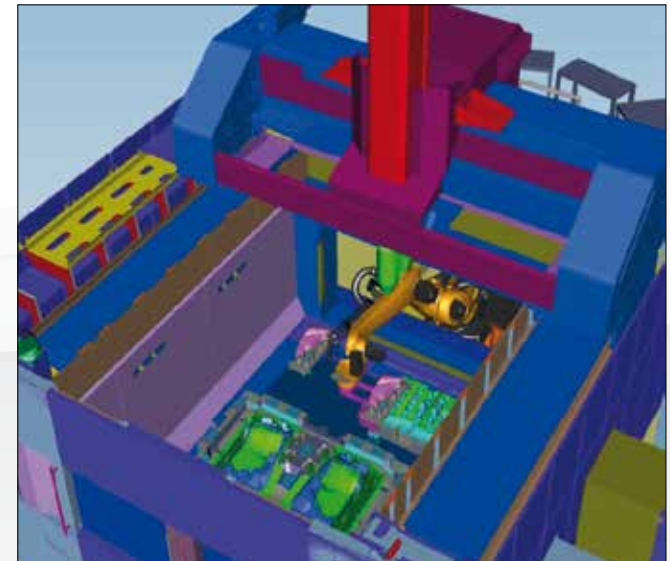
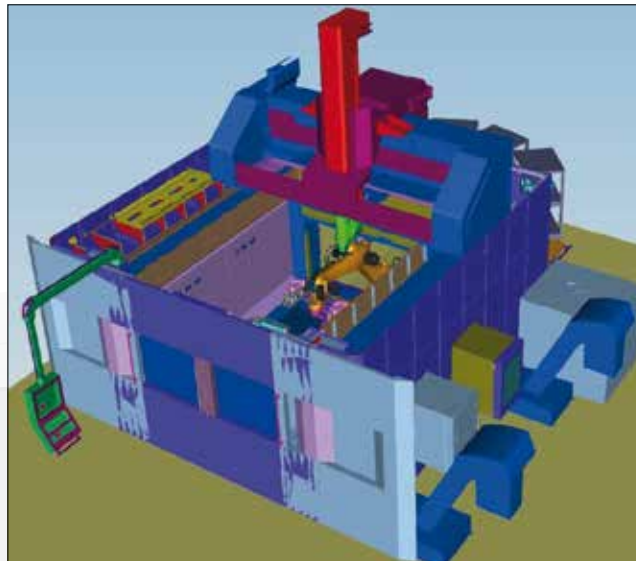

LOCKHEED MARTIN



Pratt & Whitney Aircraft

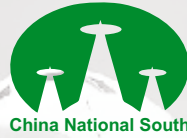

FCA
FIAT CHRYSLER AUTOMOBILES

GIUGIARO

OPEL



MECACHROME

McLaren

GM

VOLVO

sparco[®]

RONAL[®]

TESLA

MICHELIN

PIRELLI



www.gruppoparpas.com



PARPAS SpA
Via Firenze 21
35010 Cadoneghe (PD)
Tel : +39 049 700711
Fax : +39 049 703292
email : info@parpas.com



PARPAS DEUTSCHLAND
Dernauer Str. 12
D-22047 Hamburg
Tel : +49 40 18008-248
Fax : +49 40 18008-247
email : team@parpas.de



PARPAS AMERICA CORPORATION
791 Industrial Court
Bloomfield Hills, MI 48302 , USA
Tel : +1 248-253-6000
Fax : +1 248-253-6001
email : info@parpasamerica.com



PARPAS AMERICA INC.
5425 Outer Drive
Windsor, Ontario N9A 6J3, Canada
Tel : +1 248-253-6000
Fax : +1 248-253-6001
email : info@parpasamerica.com